

RAD Line IO BD

RAD Line IO – Bidirectional wireless transmission system

Data sheet
2858_en_C

© PHOENIX CONTACT 2012-11-06



1 Description

The **RAD-ISM-900-SET...BUS...** bidirectional wireless systems are pre-programmed sets of transceivers capable of transmitting and receiving wireless signals and ready for installation out of the box. Depending on the system, all that is required are antenna and I/O devices. The transmit/receive functions are managed automatically.

Each transceiver accommodates two digital signals (5 V AC/DC ... 30 V AC/DC) and one analog current signal (4 mA ... 20 mA). The signals are available at the outputs (two N/O relay contacts and one analog current output) of the other transceiver. An RF link relay diagnoses the existing wireless connection. A power LED indicates whether the wireless supply is present. The status LED indicates whether the station structure on the relevant partner is correct.

The bidirectional system can be extended by mounting additional modules via the bus foot on the side. This enables additional digital and analog signals to be acquired and transmitted.

A repeater can be added to the system. It is used to overcome large obstacles or to increase the range.



Make sure you always use the latest documentation. It can be downloaded at www.phoenixcontact.net/catalog.



This data sheet is valid for all products listed on page 3:



2 Table of contents

1	Description.....	1
2	Table of contents	2
3	Ordering data.....	3
4	Technical data	3
5	Block diagram	5
6	Safety regulation.....	6
6.1	Installation notes	6
6.2	Installation	6
6.3	Installation in the hazardous area (Division 2)	6
7	Structure	7
7.1	Display and diagnostic elements.....	8
7.2	Analog input	8
7.3	Digital inputs.....	8
7.4	Analog output	8
7.5	Digital outputs.....	8
8	Behavior in the event of the wireless connection being interrupted.....	8
9	Connection examples	9
9.1	Transceiver 1 and transceiver 2 for hold response of all outputs	9
9.2	Transceiver 1 and transceiver 2 for reset response of the digital outputs	10
9.3	Transceiver 1 and transceiver 2 for reset response of the analog outputs	11
9.4	Transceiver 1 and transceiver 2 for connection of a passive current sensor with 2-wire connection method	12
9.5	Transceiver 1 and transceiver 2 for connection of a passive current sensor with 3-wire connection method	13
10	I/O expansion module connection examples	14
10.1	RAD-IN-4A-I	14
10.2	RAD-OUT-4A-I	14
10.3	RAD-IN-8D	15
10.4	RAD-OUT-8D-REL	15
10.5	RAD-IN+OUT-2D-1A-I	16
10.6	RAD-IN-2D-CNT	16
10.7	RAD-OUT-2D-CNT	17
10.8	Avoiding ground loops	18
10.9	Installation in hazardous locations.....	20
10.10	Point-to-point.....	21
11	Hopkey	22
11.1	Replacement.....	22
11.2	HOPKEY replacement applications.....	23

3 Ordering data

Products

Description	Type	Order No.	Pcs./Pkt.
Bidirectional wireless transmission system, comprised of two transceivers and 2 dBi antennas	RAD-ISM-900-SET-BD-BUS-ANT	2867270	1
Bidirectional wireless transmission system, comprised of two transceivers (antennas are not included)	RAD-ISM-900-SET-BD-BUS	2867089	1
Bidirectional wireless transmission system comprised of one master, one repeater and one slave transceiver (antennas are not included)	RAD-ISM-900-SET-XD-BUS-REP	2902755	1
Bidirectional wireless transmission system comprised of one master and two slave transceivers (antennas are not included)	RAD-ISM-900-SET-XD-BUS-2	2902756	1

Accessories

Description	Type	Order No.	Pcs./Pkt.
Additional transceiver	RAD-ISM-900-BD-BUS	2867092	1
HOPKEY (for additional ordering data, see "Hopkey" on page 22)	RAD-ISM-900-HOP-US	2867539	1

4 Technical data

Power supply

Supply voltage U_B	24 V DC
Tolerance	-50%/+25%
Current consumption (at U_B)	
Typical	75 mA
Maximum	200 mA

Wireless interface

Frequency range	902... 928 MHz
Channel distance	22 kHz
Number of channels (groups/channels per group)	4/63
Transmission power	1 W
Antenna (2867270 only)	2 dBi omni

Analog input

Signal range	4 mA ... 20 mA
Overload capability range	10%
Underload capability range	5%
Input resistance	< 170 Ω
Resolution	16 bits
Accuracy at 25°C	0.2% of full scale
Repeatability	0.02%
Temperature coefficient at -20°C ... +65°C	0.007%/K
Power supply for passive sensors (terminal block 7)	U_B

Analog output

Signal range	4 mA ... 20 mA
Overload capability range	10%
Underload capability range	5%
Input resistance	$R_B = (U_B - 10 \text{ V})/20 \text{ mA}$
Resolution	16 bits
Accuracy at 25°C	0.2% of full scale
Repeatability	0.02%

Digital input

Signal range	5 V AC/DC ... 30 V AC/DC
High signal, minimum	5 V DC
Low signal, maximum	1.5 V DC

Digital output + RF Link

Contact type (floating N/O contact)	2 digital outputs, 1 RF link
Contact material	Ag, gold-plated
Maximum switching voltage	30 V DC, 30 V AC
Maximum switching current	0.5 A
Maximum switching frequency	1 Hz
Mechanical service life	1 x 10 ⁷ cycles
Electrical service life (at 0.5 A switching current)	8 x 10 ⁵ cycles

Climatic data

Ambient temperature	
Operation (IEC 60068-1/UL 508)	-40°C ... +70°C
Storage	-40°C ... +85°C
Relative humidity	20% ... 90%, no condensation

Indicators

RF-Link: Yellow LED	ON/OFF/flashing
Digital 1 + 2: Yellow LED	ON/OFF
Status LED: Yellow LED	ON/OFF

Housing

Housing material	Polyamide PA, non-reinforced
Degree of protection	IP20
Mounting	On NS35 DIN rail according to EN 60715
Mounting position	Any
Dimensions (W x H x D)	22.5 mm x 99 mm x 114.5 mm
Weight	520 g
Conductor cross-section	0.2 mm ² ... 2.5 mm ²

Conformance

®	Class I, Division 2 Groups A, B, C, D
FCC	Part 15.247

5 Block diagram

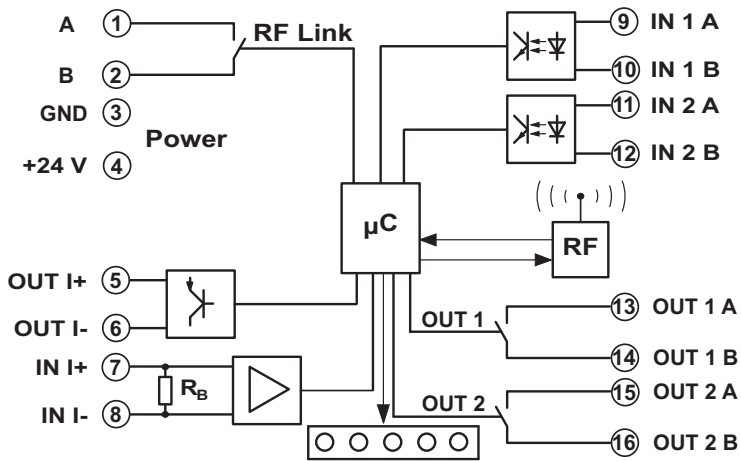

Figure 1 Block diagram

6 Safety regulation

6.1 Installation notes



The RAD-ISM-900-SET...BUS... is only for export outside of the European Economic region.



The wireless system should only be operated using authorized accessories from Phoenix Contact. The use of other accessory components may invalidate the device approval status.

6.2 Installation



WARNING:

Installation, operation, and maintenance may only be carried out by qualified electricians. Follow the installation instructions described. When installing and operating the device, the applicable regulations and safety directives (including national safety directives), as well as general technical regulations, must be observed. Observe the technical data in this data sheet and subsequent documentation (www.phoenixcontact.com).

In order to protect the modules against electrostatic discharge when working on control cabinets, the operating personnel must remove electrostatic discharge before opening control boxes or control cabinets and before touching the modules.

The modules are snapped onto a DIN rail within a control cabinet or control box.

The device must not be opened or modified. Do not repair the device yourself, replace it with an equivalent device. Repairs may only be carried out by the manufacturer. The manufacturer is not liable for damage resulting from violation.

The IP20 degree of protection of the device is intended for use in a clean and dry environment. The device must not be subject to any strain or load, which exceeds the limits described.

In the electrical system of the building, a 2-pos. disconnecting device must be provided to isolate the equipment from the supply circuit.



Observe the installation instructions for the antenna used. The antenna cable is plugged into the antenna female connector ⑪.

6.3 Installation in the hazardous area (Division 2)



The device is designed for installation in Class I, Division 2.



WARNING:

The device is not designed for use in atmospheres with a danger of dust explosions.

Observe the specified conditions for use in potentially explosive areas.

Install the device in housing (control or distributor box) that has at least IP54 protection.

Only purely resistive antennas may be operated on the devices.

These devices must be wired in accordance with Class I, Division 2 wiring methods as described in the National Electric Code, article 501-4(b) or the authority having jurisdiction.

In potentially explosive areas, snap the device on or off the bus foot and connect or disconnect the cables only when the power is disconnected.

The device must be stopped and immediately removed from the hazardous area if it is damaged or was subject to an impermissible load or stored incorrectly or if it malfunctions.

7 Structure

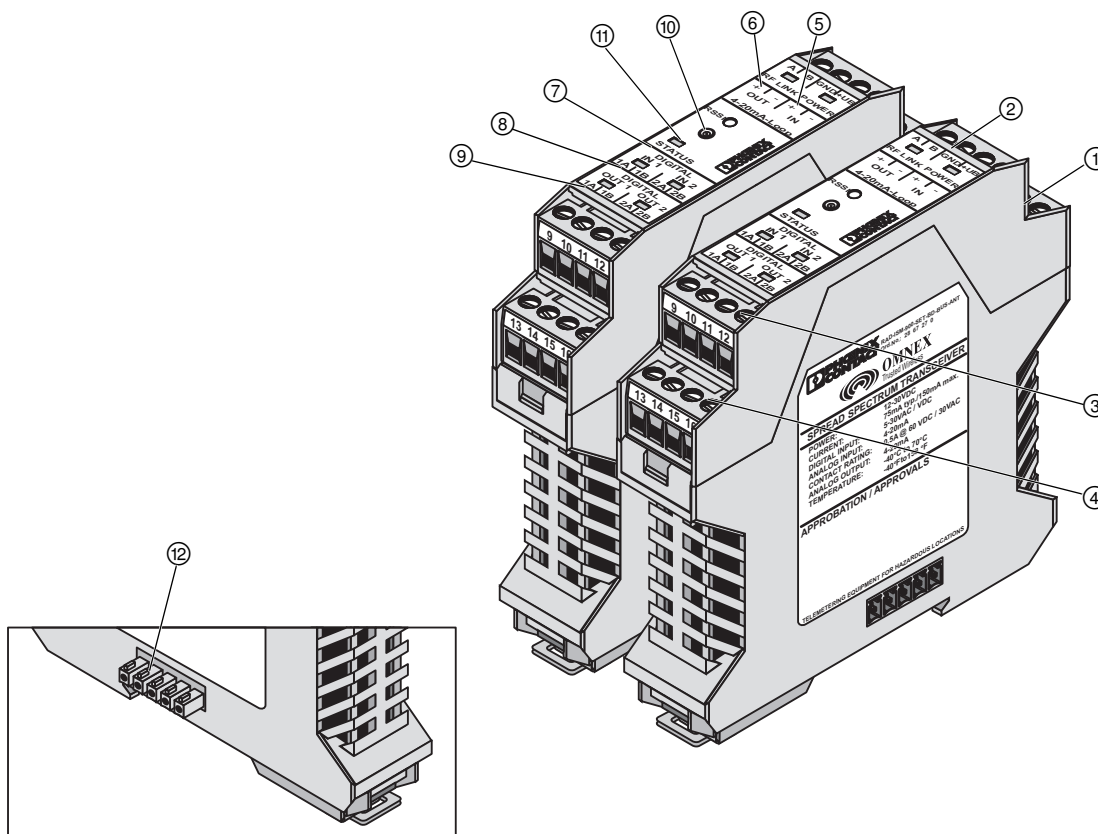

Figure 2 Components

Transmitter:

- ① Connector: Operating voltage U_B and RF link relay
- ② Connector: Analog input and output
- ③ Connector: Digital inputs 1 + 2
- ④ Connector: Digital outputs 1 + 2
- ⑤ LED: Power
- ⑥ LED: RF-Link
- ⑦ LED: Status
- ⑧ LED: Digital IN 1 + IN 2
- ⑨ LED: Digital OUT 1 + OUT 2
- ⑩ RSSI test socket
- ⑪ Antenna connection
- ⑫ Bus foot

7.1 Display and diagnostic elements

- 1 RF link relay
The RF link relay in the transceiver diagnoses the status of the wireless connection. It picks up when the wireless connection is established. If no data packets are received correctly over a period of approximately 5 seconds, the relay drops again. It picks up again automatically when the wireless connection is re-established. The RF link relay has been designed as an N/O contact.
- 5 LED: Power
ON = Operating voltage U_B present
- 6 LED: RF-Link
OFF = Operating voltage U_B not present
Flashes briefly approximately every 2 seconds = No reception
Flashes quickly = Weak connection
ON = Wireless connection established
- 7 LED: Status
Station structure is OK (all modules are addressed correctly)
- 8 LED: Digital IN 1 + IN 2 = Status of the digital inputs
- 9 LED: Digital OUT 1 + OUT 2 = Status of the digital outputs
- 10 RSSI test socket
A voltage measuring device (handheld multimeter) can be connected to the RSSI test socket to measure a voltage, which provides information about the received wireless signal. The received signal strength in dB can be determined using the voltage value (see Table 1). This can be useful when positioning and aligning the antenna, for example.

Table 1 RSSI vs. voltage

dBi	RSSI (V)	
-110	0.5	No connection [1]
-105	1.0	
-100	1.5	Poor connection [2]
-95	2.0	
-90	2.5	Good connection [3]
-85	3.0	
-80	3.5	

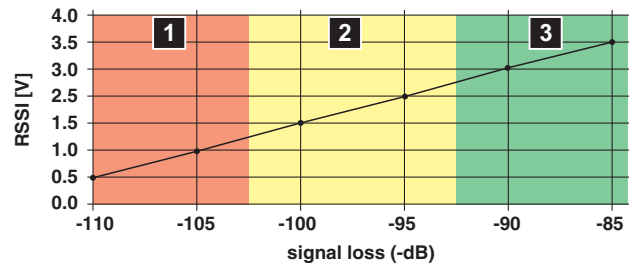

Figure 3 RSSI graph

7.2 Analog input

The 4 mA ... 20 mA analog input (2) detects active and passive current sensors (see "Connection examples" on page 9).

7.3 Digital inputs

Both digital inputs (3) of the transmitter can process voltages from 5 V AC/DC ... 30 V AC/DC. They are electrically isolated from the operating voltage U_B .

7.4 Analog output

The analog output (2) is a passive output. The internal power supply can be used to supply the actuator.

The output requires an internal drop voltage of 10 V.

The maximum load at the current output with a nominal voltage of 24 V = $(24 V - 10 V) / 20 mA = 700 \Omega$. Therefore, the maximum load depends on the operating voltage U_B used.

7.5 Digital outputs

Two floating N/O contacts are used as the digital outputs (3) for the transceiver.

8 Behavior in the event of the wireless connection being interrupted

If the wireless connection is interrupted, all outputs (analog and digital) retain their last value or status (see connection examples).

To configure a reset response (revert back to "0") for a digital signal or the analog signal when a wireless connection is interrupted, connect the RF link relay contact in series, for example.

To configure a reset response for all signals, use the RF link relay to control one or more additional relays.

9 Connection examples

9.1 Transceiver 1 and transceiver 2 for hold response of all outputs

Both transceivers have the same structure.

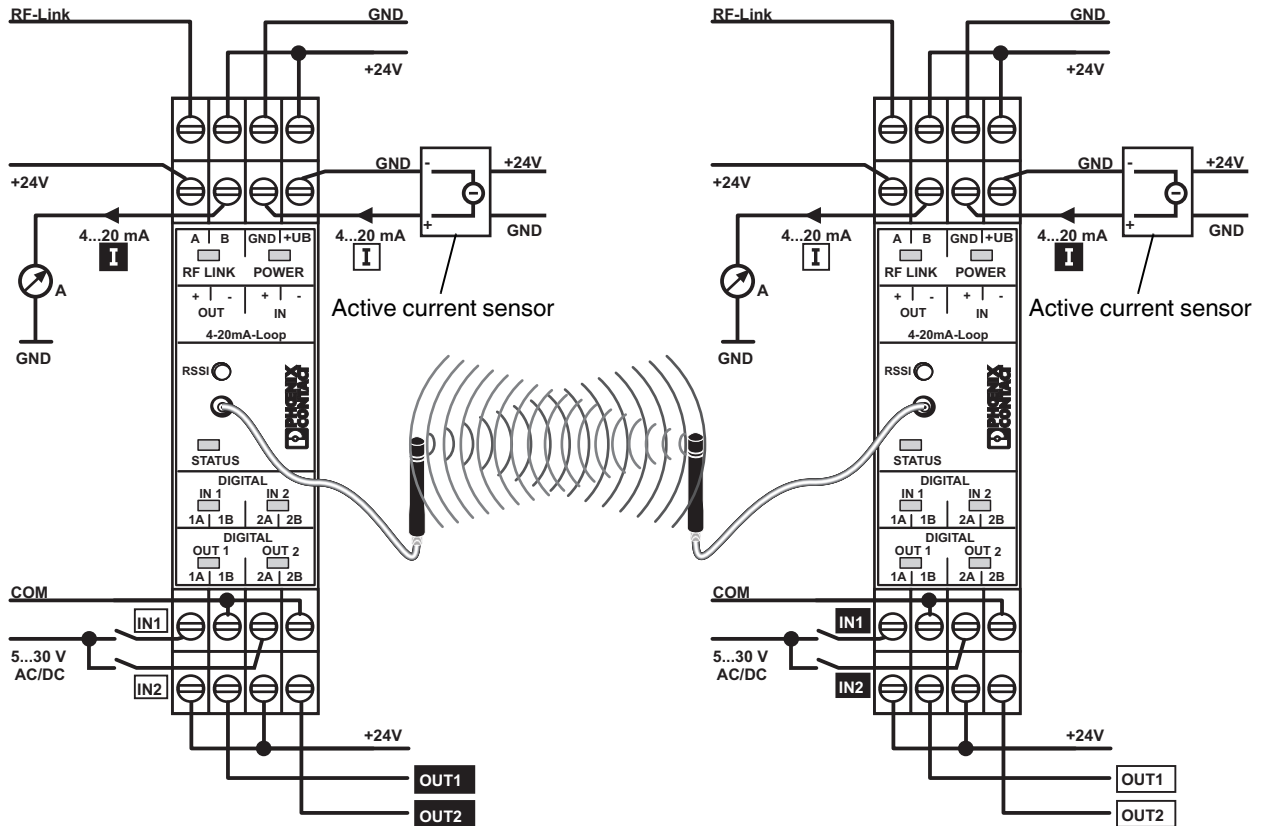

Figure 4 Transceiver 1 and transceiver 2 for hold response of all outputs

9.2 Transceiver 1 and transceiver 2 for reset response of the digital outputs

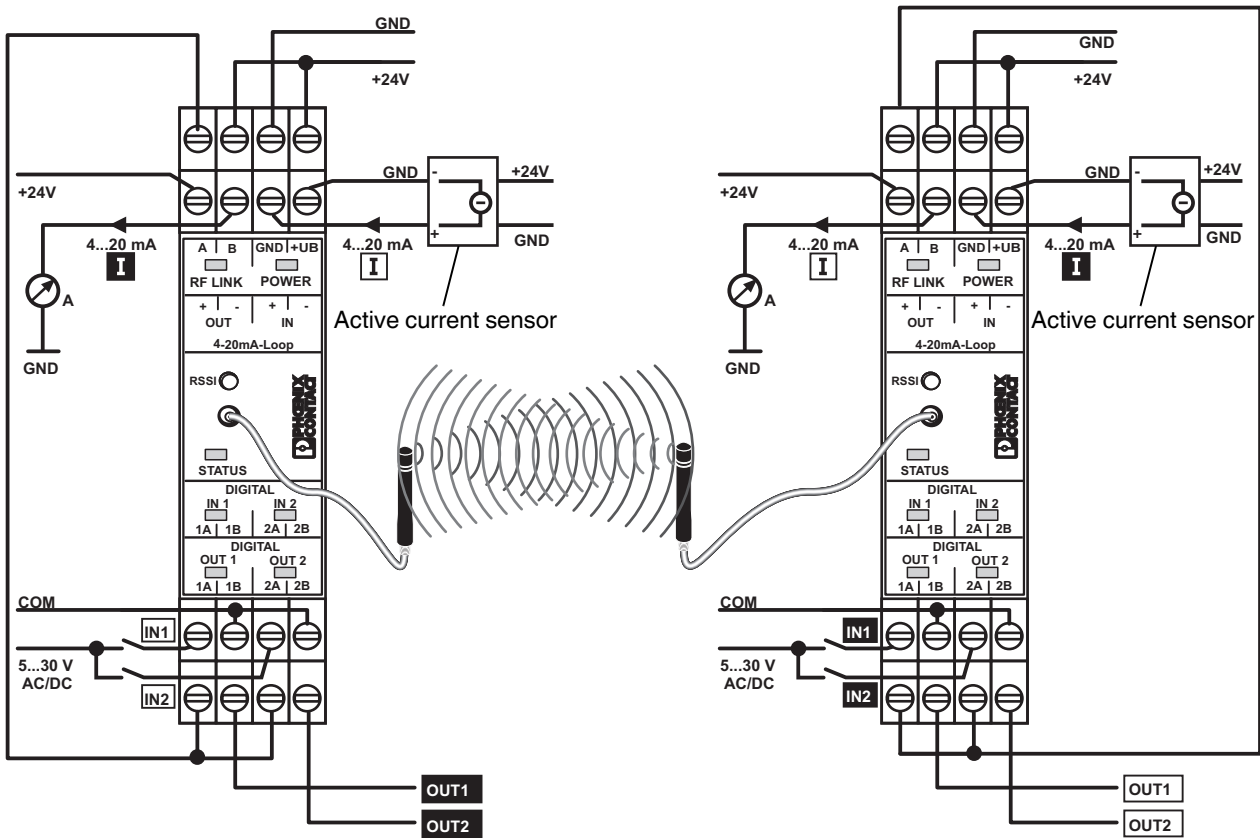

Figure 5 Transceiver 1 and transceiver 2 for reset response of the digital outputs

9.3 Transceiver 1 and transceiver 2 for reset response of the analog outputs

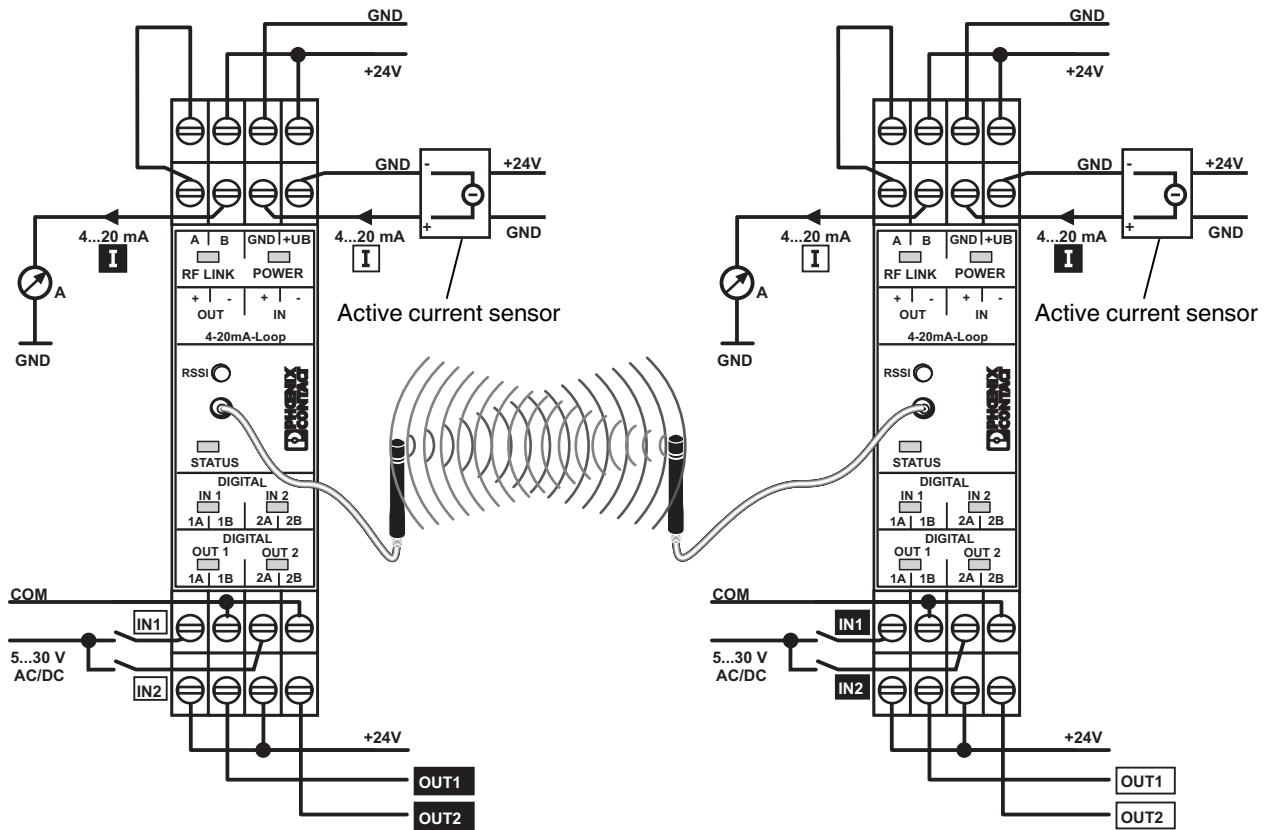

Figure 6 Transceiver 1 and transceiver 2 for reset response of the analog outputs

9.4 Transceiver 1 and transceiver 2 for connection of a passive current sensor with 2-wire connection method

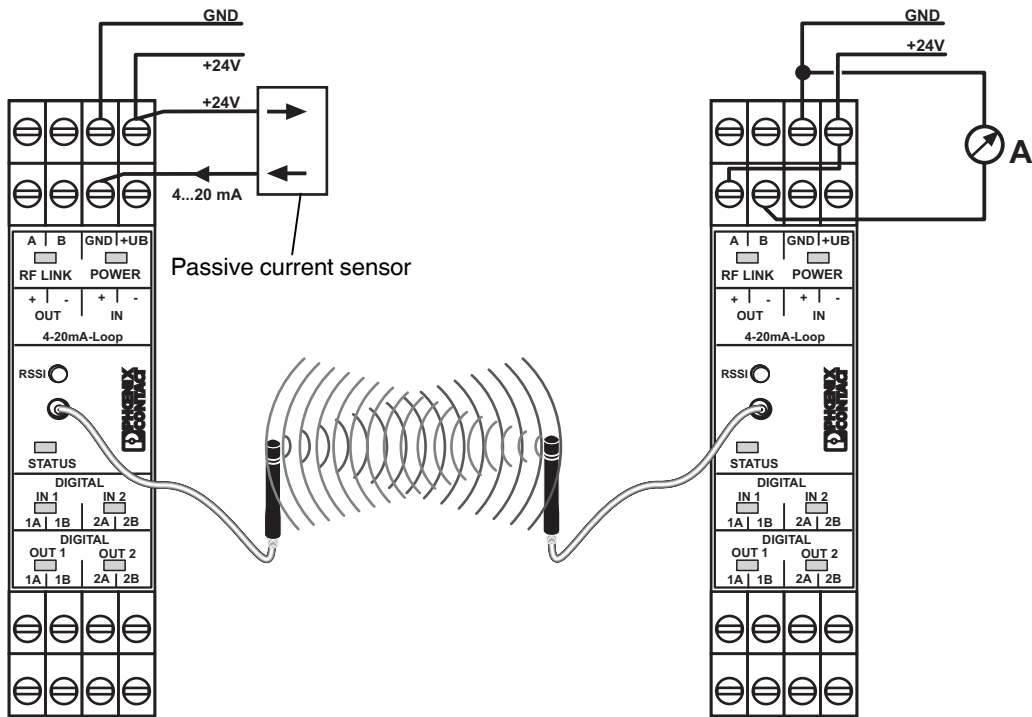

Figure 7 Transceiver 1 and transceiver 2 for connection of a passive current sensor with 2-wire connection method

9.5 Transceiver 1 and transceiver 2 for connection of a passive current sensor with 3-wire connection method

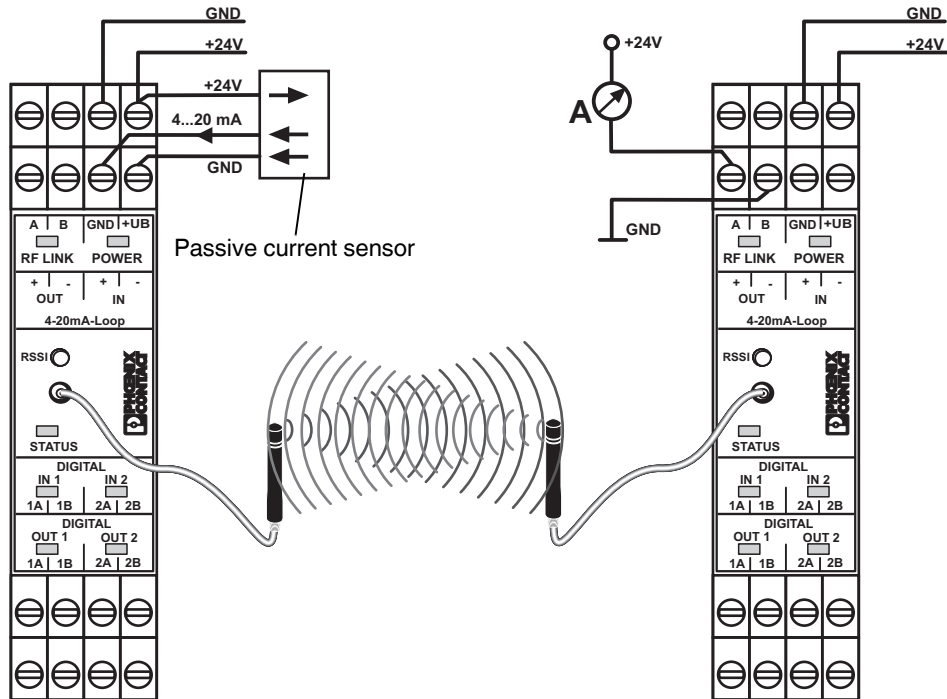

Figure 8 Transceiver 1 and transceiver 2 for connection of a passive current sensor with 3-wire connection method

10 I/O expansion module connection examples

10.2 RAD-OUT-4A-I

10.1 RAD-IN-4A-I

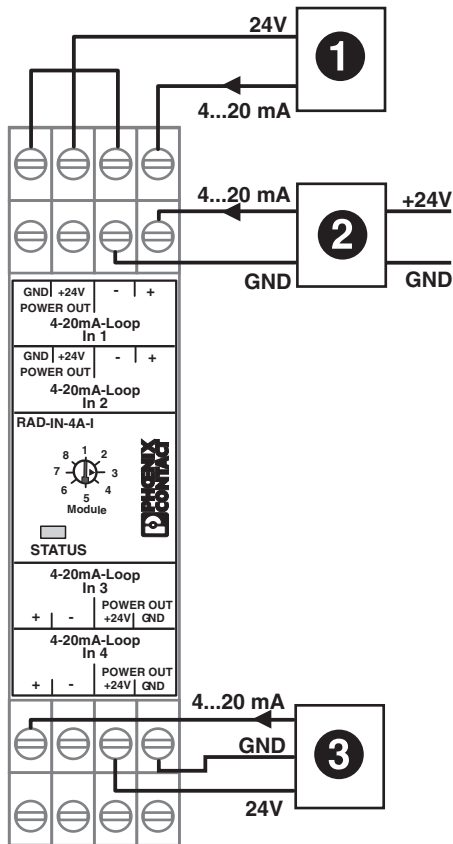

Figure 9 Connection example for the RAD-IN-4A-I

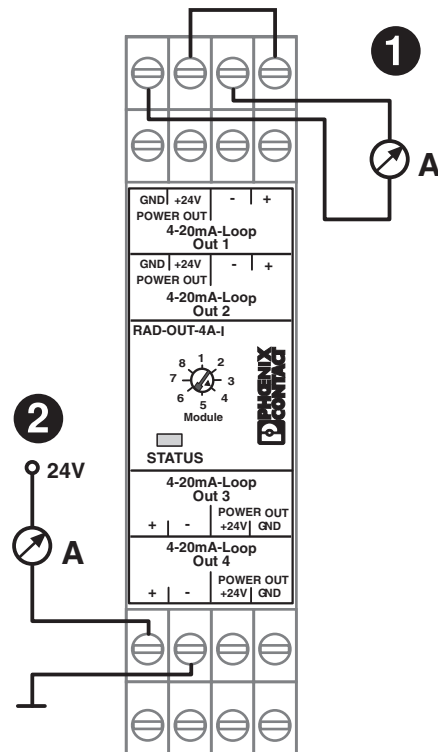

Figure 10 Connection example for the RAD-OUT-4A-I

10.3 RAD-IN-8D

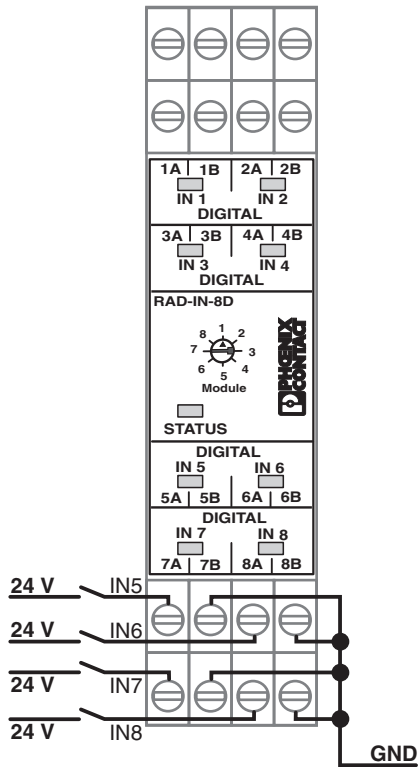

Figure 11 Connection example for the RAD-IN-8D

10.4 RAD-OUT-8D-REL

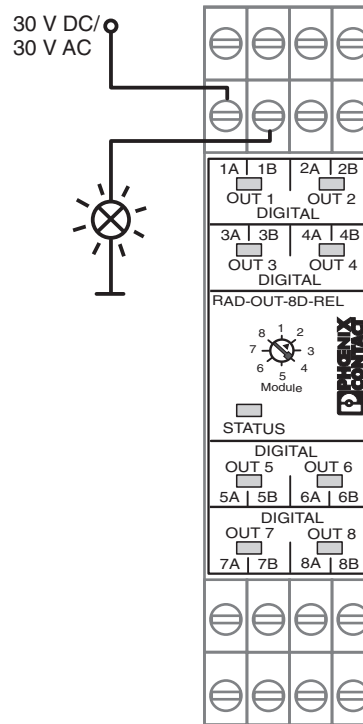

Figure 12 Connection example for the RAD-OUT-8D-REL

10.5 RAD-IN+OUT-2D-1A-I

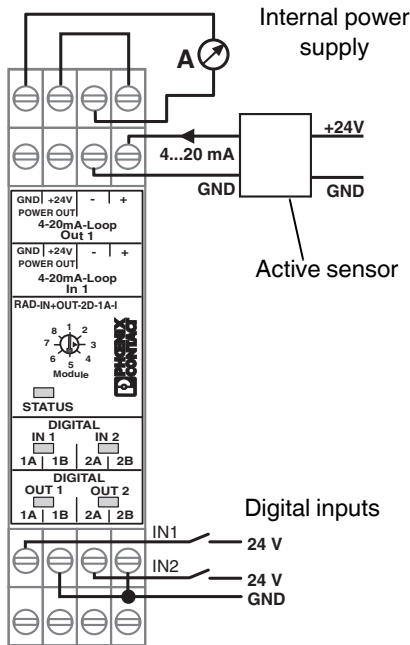

Figure 13 Digital input connection example for the RAD-IN+OUT-2D-1A-I

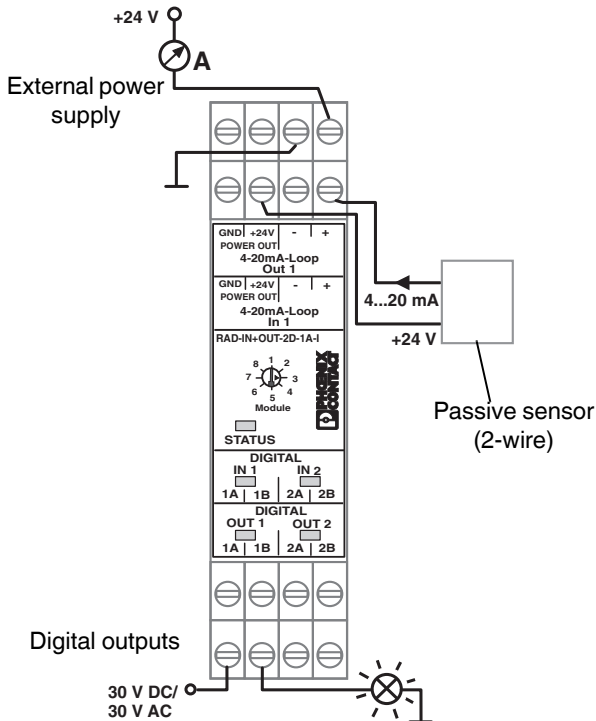

Figure 14 Digital output connection example for the RAD-IN+OUT-2D-1A-I

10.6 RAD-IN-2D-CNT

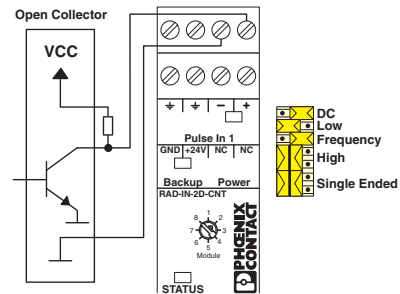

Figure 15 Open collector example for the RAD-IN-2D-CNT

Recommended DIP switch settings:

- DIP 1 "Coupling": DC
- DIP 2 "Impedance": LOW
- DIP 3 "Operation Mode": Depending on the application: either in counter or in frequency mode
- DIP 4 "Speed": Depending on the application: if the pulse length of the pulses to be measured is at least 100 ms or greater, the low pass filter can be activated (DIP to low) to suppress interference. If you are measuring shorter signal lengths, set the DIP switch to high.
- DIP 5 "Sensor Input": Single ended

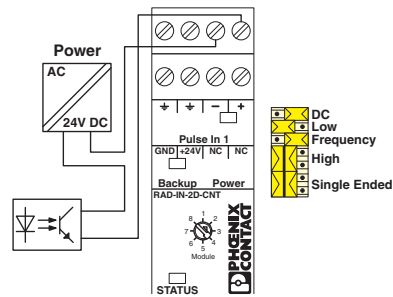

Figure 16 Optocoupler or relay example for the RAD-IN-2D-CNT

Recommended DIP switch settings:

- Same as for the Open collector example (see Figure 15).

For relay applications:

- Set DIP 4 "Speed" to low to compensate for contact chatter.

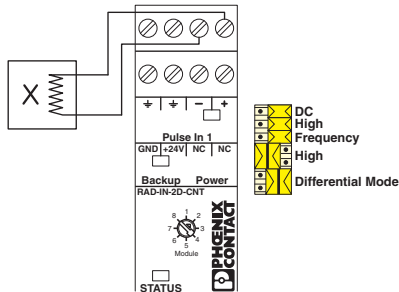

Figure 17 Magnetic measuring transducer for the RAD-IN-2D-CNT

Recommended DIP switch settings:

- DIP 1 "Coupling": DC
- DIP 2 "Impedance": HIGH
- DIP 3 "Operation Mode": Depending on the application: either in counter or in frequency mode
- DIP 4 "Speed": HIGH
- DIP 5 "Sensor Input": Differential mode

10.7 RAD-OUT-2D-CNT

Switched load

The integrated transistor in the module output can switch loads, such as relays or optocouplers. A self-resetting fuse protects the transistor against damage due to short circuit. The switch position of the DIP switches should be selected according to the application as described in DIP switches.

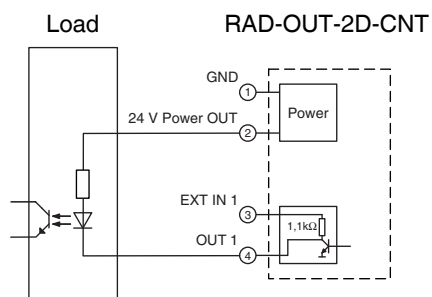

Figure 18 Passive load with an optocoupler for the RAD-OUT-2D-CNT

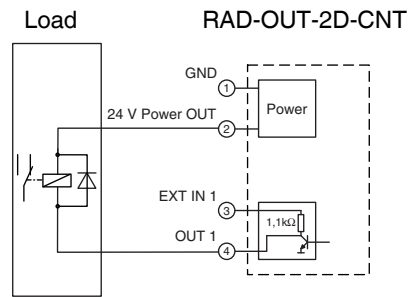

Figure 19 Passive load with a relay for the RAD-OUT-2D-CNT

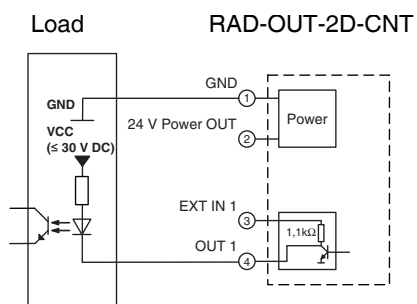

Figure 20 External power supply load with an optocoupler for the RAD-OUT-2D-CNT

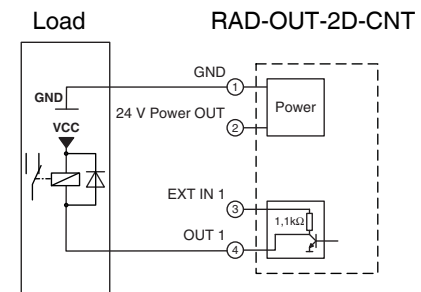

Figure 21 External power supply load with an optocoupler for the RAD-OUT-2D-CNT

Voltage output for subsequent control systems

If the downstream electronics requires a HIGH/LOW voltage level, the required communications power can be connected to the EXT terminal block. The logic ground must also be connected to the module ground (OUT GND terminal block). The HIGH/LOW signal can then be picked up at the OUT terminal block.

The switch position of the DIP switches should be selected according to the application.

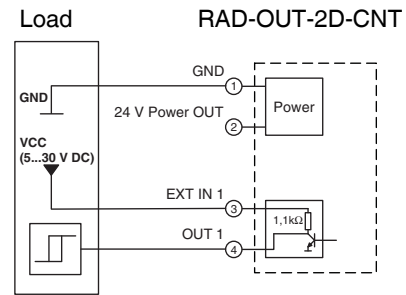

Figure 22 Voltage output for subsequent control systems for the RAD-OUT-2D-CNT

10.8 Avoiding ground loops



NOTE: Device damage caused by compensating currents

Differential voltages may occur between the potentials when the ground connections are physically separated. These voltages may cause compensating currents over the low-resistance path marked in red. Just a few volts can cause compensating currents in the range of several amperes, which may damage the device.

Figure 23 shows the course of the compensating currents, which is created when different supply voltage sources are used for the sensor and the RAD-ISM-... device, and when the two sources have a separate ground reference. This arrangement (using different sources for sensor and RAD-ISM-... system) does not always cause problems. However, high compensating

currents (in the range of several amperes) may cause damage to the device. To avoid these effects, the complete arrangement must only be grounded at one central point (e.g., not using the connection to PE2).

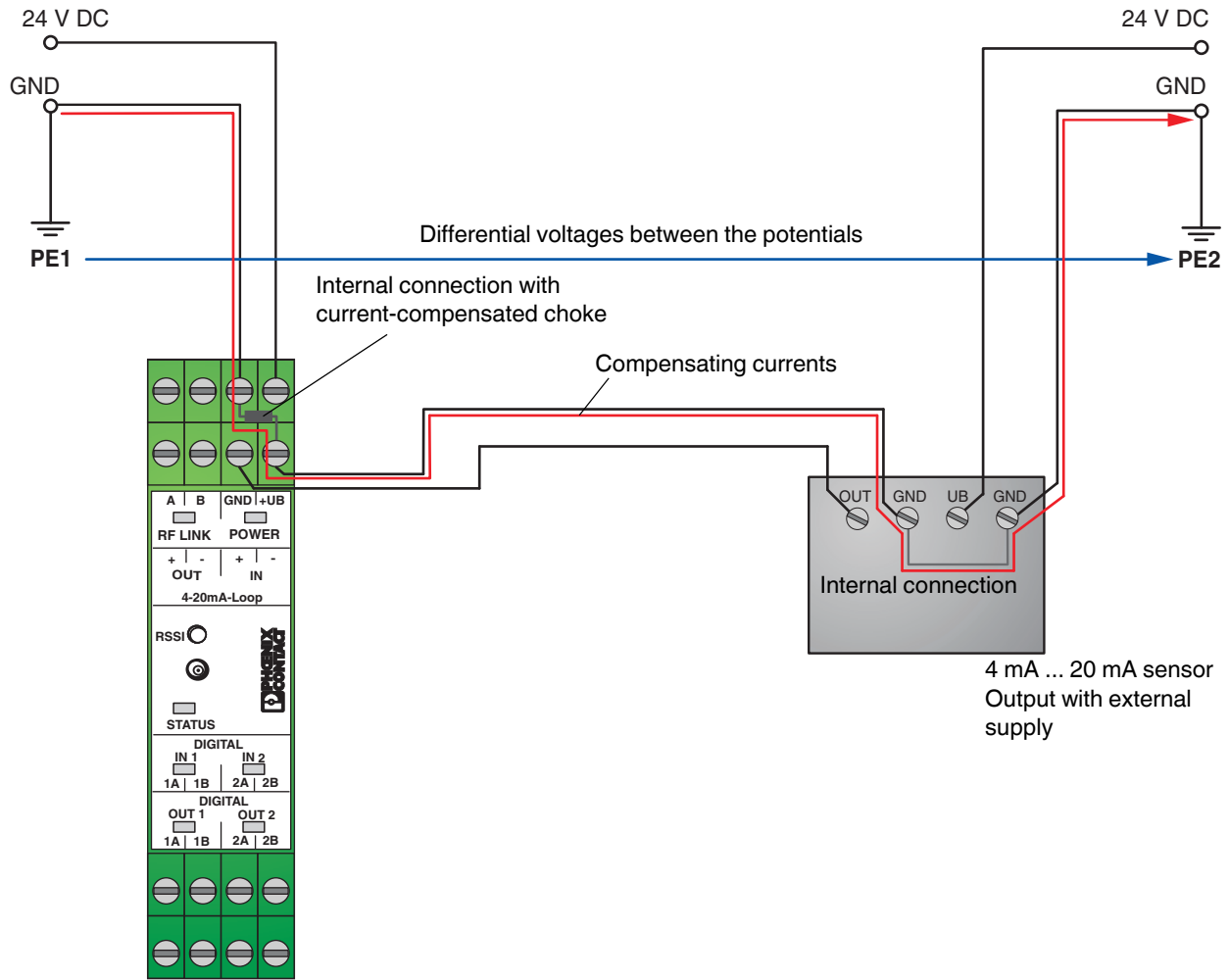

Figure 23 Avoiding ground loops

10.9 Installation in hazardous locations

With certification according to UL, the RAD-ISM-900-SET...BUS... bidirectional wireless system can be used in the hazardous area of division 2 with hazardous gases. Signals from outside the hazardous area as well as signals from division 2 can be connected directly. Signals from zones 1 and 0 cannot be connected directly. They can only be connected via the appropriate barriers because the inputs are not intrinsically safe.

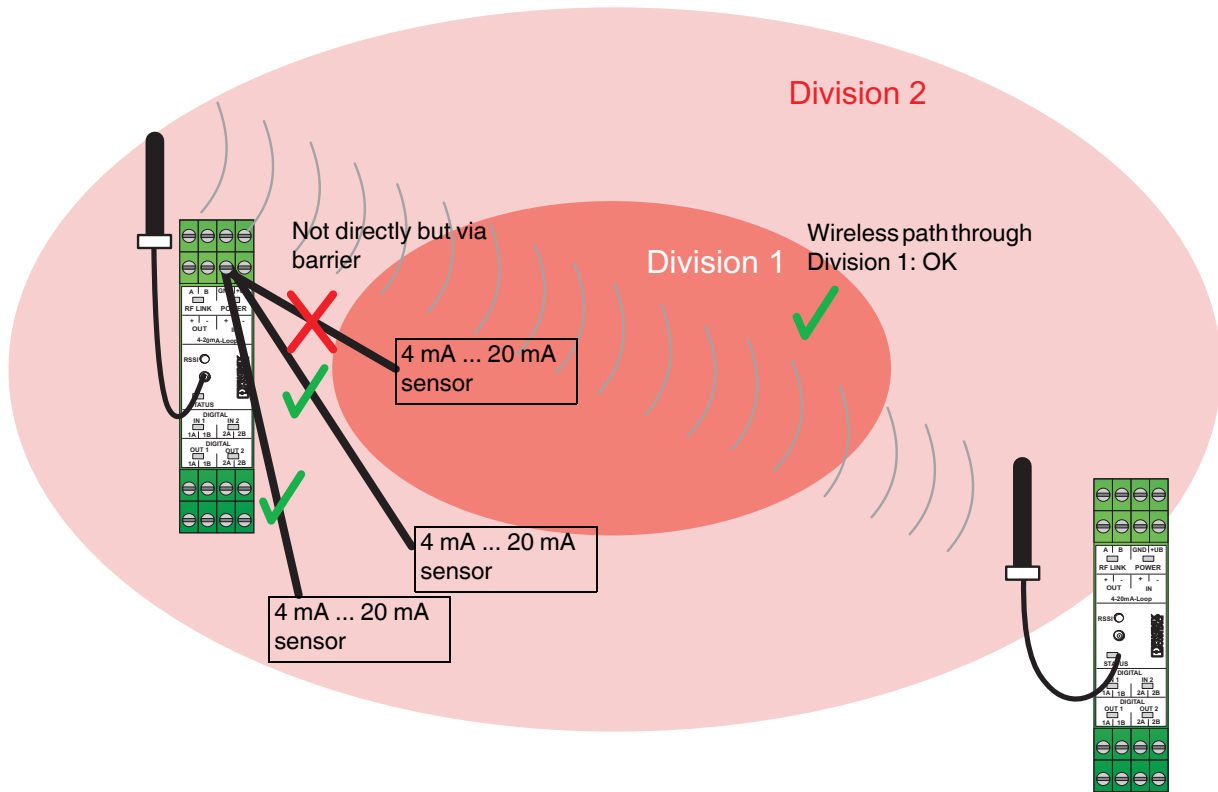

Figure 24 RAD-ISM-900-SET...BUS... with UL/cUL approval for use in Class I, Division 2 areas

10.10 Point-to-point

Point-to-point

In the point-to-point system version, the set is installed, the signals are connected, and the operating voltage is applied. The wireless connection is established automatically - no other settings are required.

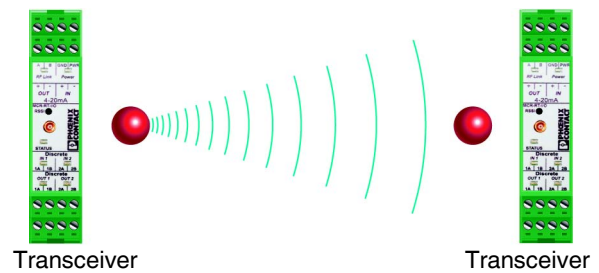

Figure 25 Point-to-point

Point-to-point with extension modules

When extension modules are used, they are mounted via the bus foot on the side. A maximum of eight extension modules can be mounted. The modules are assigned to one another via an address encoding switch on the front of the module.

Please note, for example, that an 8-channel digital input module (RAD-IN-8D) (module 1 in Figure 26) is assigned to an 8-channel digital output module (RAD-OUT-8D-REL) (module a in Figure 26) on the other station side (→same address). The status LED indicates whether the system structure is correct (ON = OK; flashing = error).

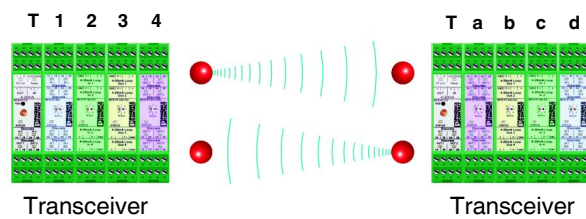

Figure 26 Point-to-point with extension modules

Point-to-multipoint

For a bidirectional point-to-multipoint system, use the RAD-ISM-900-SET-XD (Order No. 5605715).

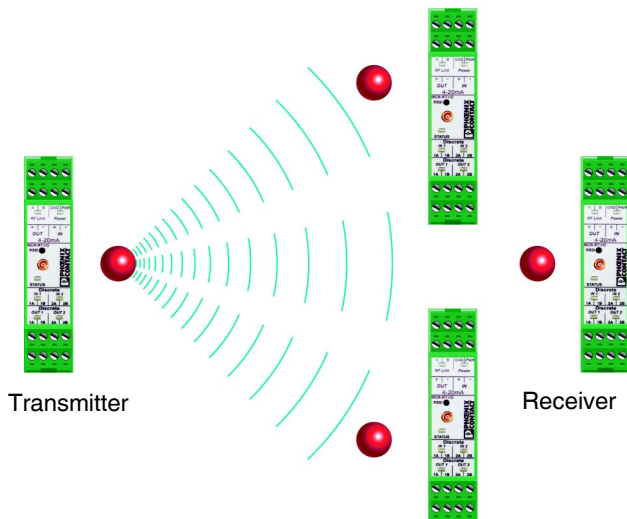

Figure 27 Point-to-multipoint

Repeater system

Repeaters can be used to overcome large obstacles (e.g., mountain tops) or to increase the range.

Repeaters are simple transceivers with a special HOPKEY.

To extend an existing point-to-point system with a repeater, an additional transceiver (RAD-ISM-900-BD-BUS, Order No. 2867092) and a HOPKEY with repeater configuration are required for the existing set.



Important: Bidirectional data exchange is also possible with extension modules in a point-to-point connection with a repeater.

Signals cannot be detected or output at the repeater. The cycle time when transmitting in one direction doubles from 37 ms to 74 ms.

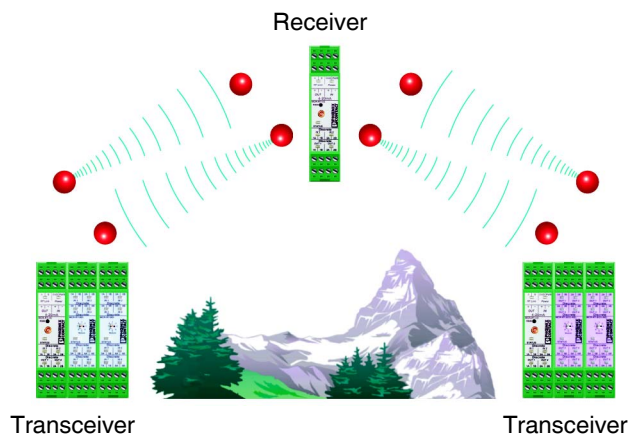

Figure 28 Repeater system

Multi-repeater system

Any number of repeaters can be integrated in one system. Please note that the cycle time increases by 37 ms for each repeater.

Example: In the figure opposite, a signal requires at least 4 x 37 ms to go from A to B and just as long to come back again. A complete system update, therefore, takes at least 8 x 37 ms.

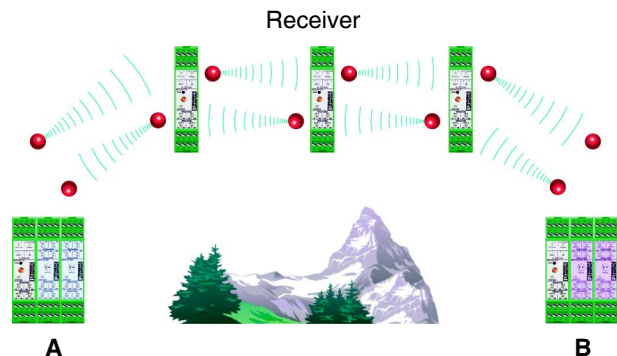

Figure 29 Multi-repeater system

11 Hopkey

11.1 Replacement

The HOPKEY (Order No. 2867539) must be replaced when replacing faulty transceivers or when extending a system to create multi-receiver or repeater systems.

To order a HOPKEY, the HOPKEY ID and serial numbers of the existing devices must be supplied along with the desired HOPKEY type, i.e., master, repeater, slave.

The HOPKEY contains information such as the transmission frequencies used and the hop sequence. This information is required when installing an additional receiver/repeater in an existing system.

To install a HOPKEY, proceed as follows:

1. To protect the modules against ESD, the operating personnel must remove electrostatic discharge at appropriate points (e.g., control cabinet) before touching the modules.
2. The existing system must have established a wireless connection.
3. Disconnect the power to the existing system.
4. Open the housing of the transceiver in the existing system by pressing both housing latches on the sides. Remove the electronics module from the housing (see Figure 30).
5. At the bottom right on the PCB is a small PCB in a 10-pos. base – this is the HOPKEY. Remove the HOPKEY and insert it in the same position in the new transceiver that you wish to install (see Figure 31).

6. Close all the housing covers and reinsert the modules in the control cabinet(s).
7. Reconnect the supply voltage – the new transceiver now also operates in the existing system.
8. Repeat the procedure for all additional receivers/repeaters.

Explanation:

When the supply voltage is connected, the information is transmitted from the connected HOPKEY to a non-volatile memory inside the module. This HOPKEY can then be used to "teach" other receivers. The HOPKEY can be stored in the last receiver.

If no HOPKEY is connected, the information inside the module is used.

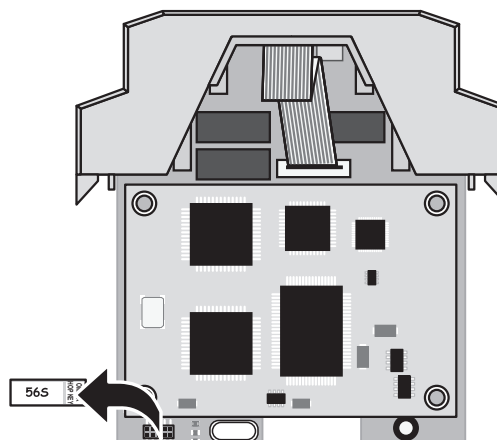

Figure 31 Inserting the HOPKEY

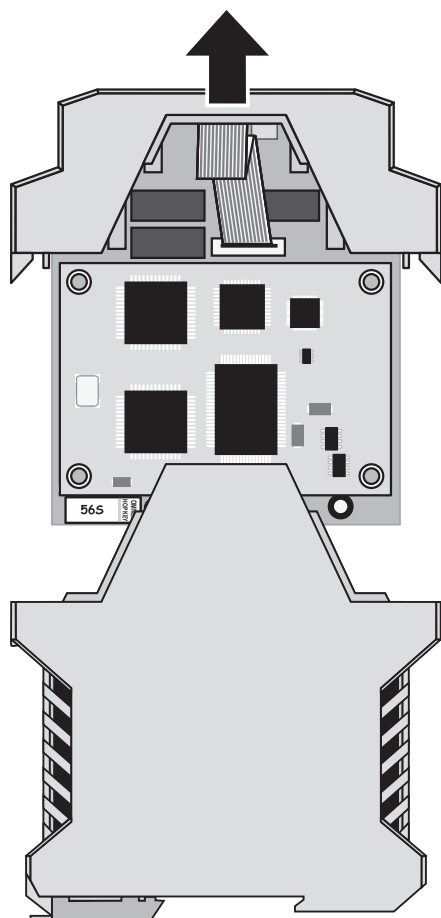

Figure 30 Removing the electronics module

11.2 HOPKEY replacement applications

Replacing a faulty transceiver in a point-to-point system

If a faulty transceiver has to be replaced, only one replacement module (RAD-ISM-900-SET-BD-BUS, Order No. 2867092) is required.

- Remove the HOPKEY from the faulty module and insert it in the replacement device. The system continues to operate after switching on the supply voltage.

If a HOPKEY is ever lost in a point-to-point system, an appropriate replacement can be ordered as follows. Check whether "M" or "S" is specified next to the identification number (ID) on the HOPKEY. In a point-to-point system, **one** HOPKEY with "IDxxxxxM" and **one** HOPKEY with "IDxxxxxS" must always be available. Order as follows:

Type	Order No.	Pcs./ Pkt.	Additional ordering data
RAD-ISM-900-HOP-US	2867539	1	IDxxxxx, PPM = Type M

Repeater function in the point-to-point system

If an existing point-to-point system is to be extended by one or more repeaters, at least one transceiver (Order No. 2867092) is required for your RAD-ISM-900-SET-BD-BUS, as well as the following HOPKEY:

Type	Order No.	Pcs./ Pkt.	Additional ordering data
RAD-ISM-900-HOP-US	2867539	1	IDxxxxx, REP = Type

The HOPKEY is installed in the additional transceiver. If additional repeaters are used, the HOPKEY is replaced by the additional transceivers one after the other.